



80V/90A N-Channel Advanced Power MOSFET

Features

- Lead free and Green Device Available.
- Low Rds-on to Minimize Conductive Loss
- High avalanche Current
- 100% Avalanche Tested

Applications

- Power Supply
- DC-DC Converters
- Uninterruptible Power Supply (UPS)
- Battery Managemer

BVDSS	80	V
ID	90	A
RDSON@VGS=10V	6.9	mΩ

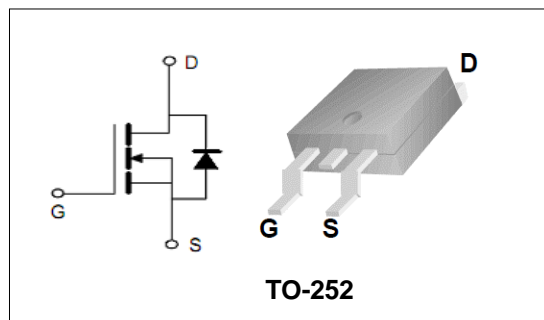

Order Information

Product	Package	Marking	Reel Size	Reel	Carton
PTD90N08	TO-252	PTD90N08	13inch	2500PCS	50000PCS

Absolute Maximum Ratings

Symbol	Parameter	Rating	Unit	
Common Ratings (TC=25°C Unless Otherwise Noted)				
$V_{(BR)DSS}$	Drain-Source Breakdown Voltage	80	V	
V_{GS}	Gate-Source Voltage	±20	V	
T_J	Maximum Junction Temperature	150	°C	
T_{STG}	Storage Temperature Range	-55 to 150	°C	
I_S	Diode Continuous Forward Current	TC =25°C	90	A
Mounted on Large Heat Sink				
E_{AS}	Single Pulse Avalanche Energy (Note1)	313	mJ	
I_{DM}	Pulse Drain Current Tested (Silicon Limit) (Note2)	TC =25°C	360	A
I_D	Continuous Drain current	TC =25°C	90	A
P_D	Maximum Power Dissipation	TC =25°C	95	W
$R_{θJC}$	Thermal Resistance-Junction to Case (Note3)	1.32	°C/W	

**80V/90A N-Channel Advanced Power MOSFET**

Symbol	Parameter	Condition	Min.	Typ.	Max.	Unit
Static Electrical Characteristics @ TJ = 25°C (unless otherwise stated)						
$V_{(BR)DSS}$	Drain- Source Breakdown Voltage	VGS=0V ID=250μA	80	--	--	V
I_{DSS}	Zero Gate Voltage Drain current	VDS=80V,VGS=0V	--	--	1	μA
I_{GSS}	Gate-Body Leakage Current	VGS=±20V,VDS=0V	--	--	±100	nA
$V_{GS(TH)}$	Gate Threshold Voltage	VDS=VGS,ID=250μA	2	3	4	V
$R_{DS(ON)}$	Drain-Source On-State Resistance (Note4)	VGS=10V, ID=40A	--	6.9	8	mΩ
Dynamic Electrical Characteristics @ TJ = 25°C (unless otherwise stated) (Note5)						
C_{iss}	Input Capacitance	VDS=50V,	--	3175	--	pF
C_{oss}	Output Capacitance	VGS=0V,	--	440	--	pF
C_{rss}	Reverse Transfer Capacitance	F=1MHz	--	268	--	pF
Q_g	Total Gate Charge	VDS=64V,	--	76	--	nC
Q_{gs}	Gate-Source Charge	ID=50A,	--	21	--	nC
Q_{gd}	Gate-Drain Charge	VGS=10V	--	24	--	nC
Switching Characteristics (Note5)						
$t_{d(on)}$	Turn-on Delay Time	VDS=40V, ID=50A, VGS=10V	--	49	--	nS
t_r	Turn-on Rise Time		--	64	--	nS
$t_{d(off)}$	Turn-off Delay Time		--	139	--	nS
t_f	Turn-off Fall Time		--	48	--	nS
Source- Drain Diode Characteristics @ TJ = 25°C (unless otherwise stated)						
V_{SD}	Forward on voltage	ISD=50A,VGS=0V	--	--	1.3	V
t_{rr}	Reverse Recovery Time	IS=50A, dI/dt=100A/us	--	45	--	nS
Q_{rr}	Reverse Recovery Charge		--	65	--	nC

Note:

- Limited by TJmax, starting TJ = 25° C, RG = 25Ω, VD = 25V, VGS = 10V. Part not recommended for use above this value.
- Repetitive Rating: Pulse width limited by maximum junction temperature.
- Surface Mounted on FR4 Board, t ≤ 10 sec.
- Pulse Test: pulse width ≤ 300 us, duty cycle ≤ 2%.
- Guaranteed by design, not subject to production testing.



80V/90A N-Channel Advanced Power MOSFET

Typical Characteristics

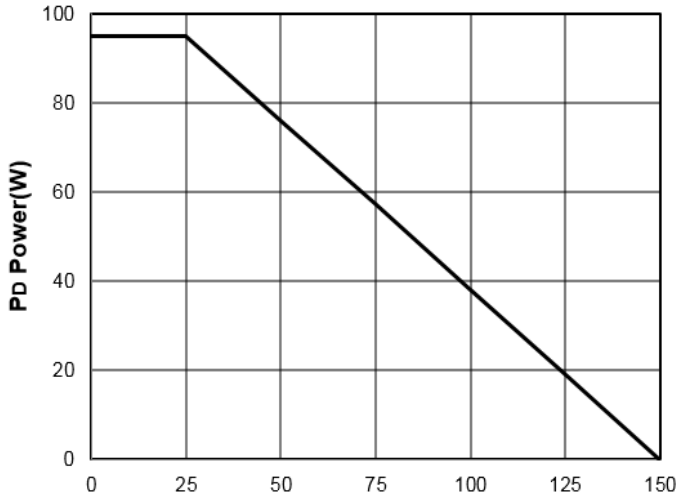

Figure1: Tj Junction Temperature (°C)

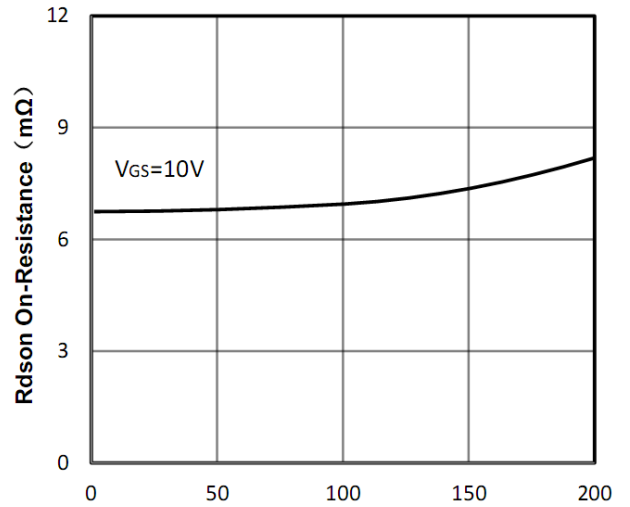

Figure2: Id Drain Current (A)

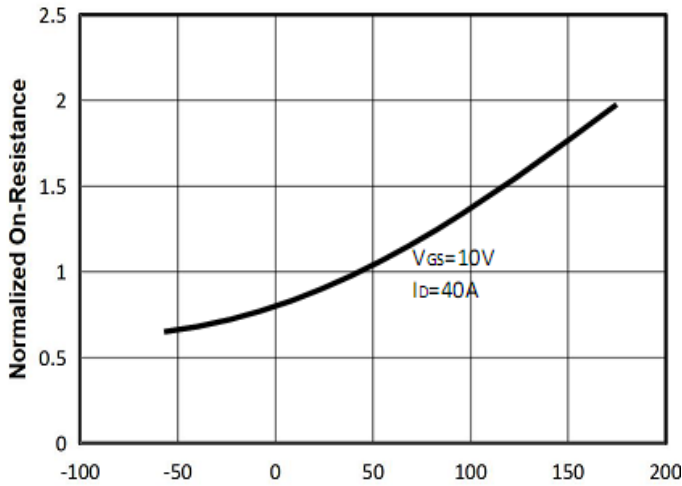

Figure3: Tj Junction Temperature (°C)

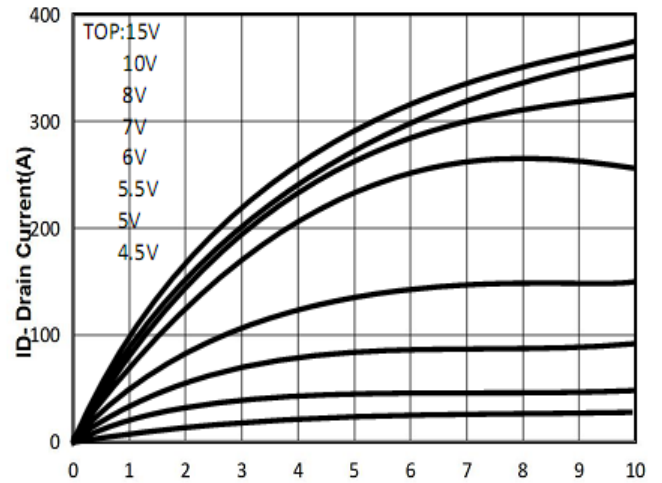

Figure4: Vds Drain-Source Voltage (V)

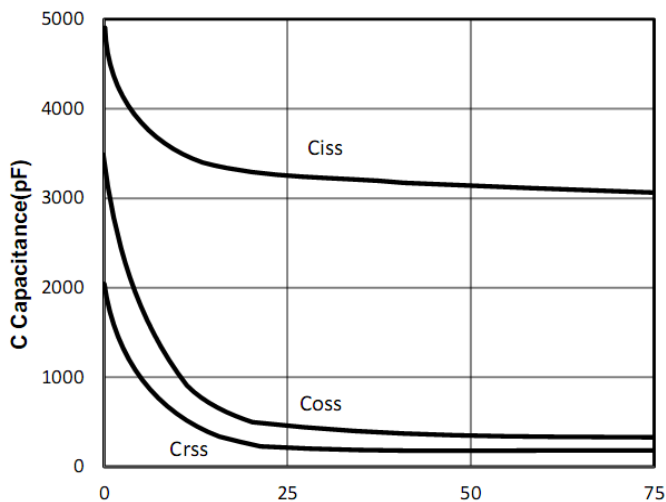

Figure5: Vds Draun-Source Voltage (V)

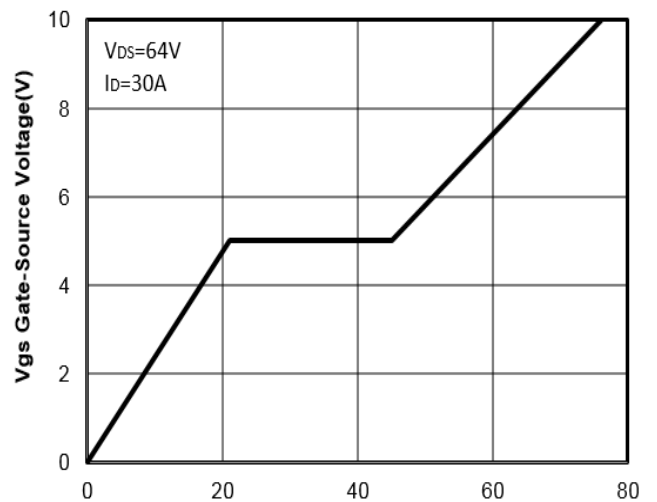

Figure6: Qg Gate Charge (nC)



80V/90A N-Channel Advanced Power MOSFET

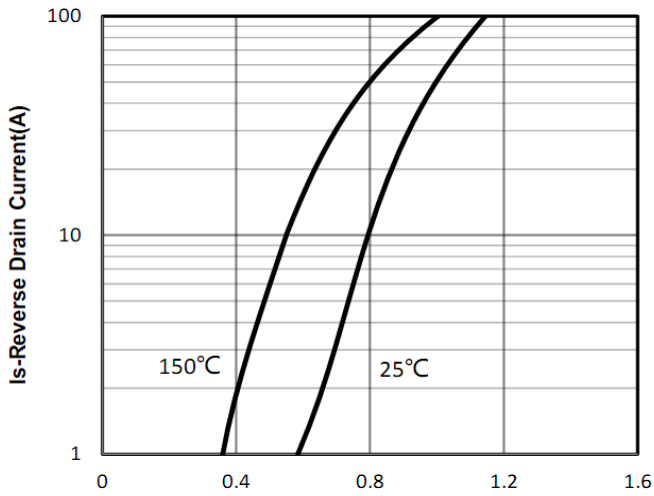

Figure7: Vsd Source-Drain Voltage (V)

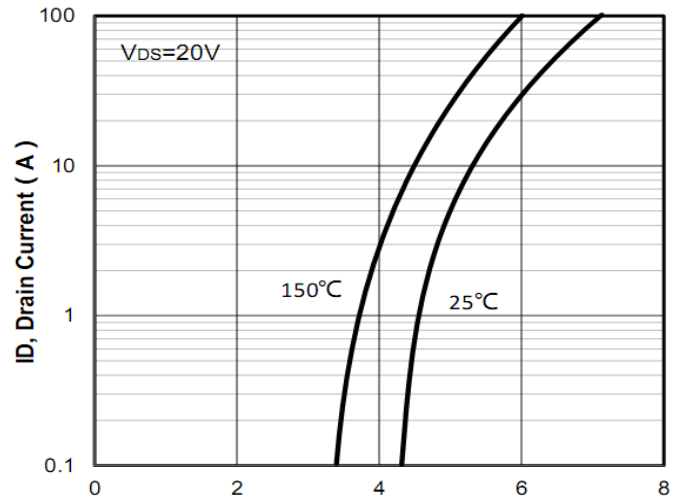

Figure8: Vgs Gate-Source Voltage (V)

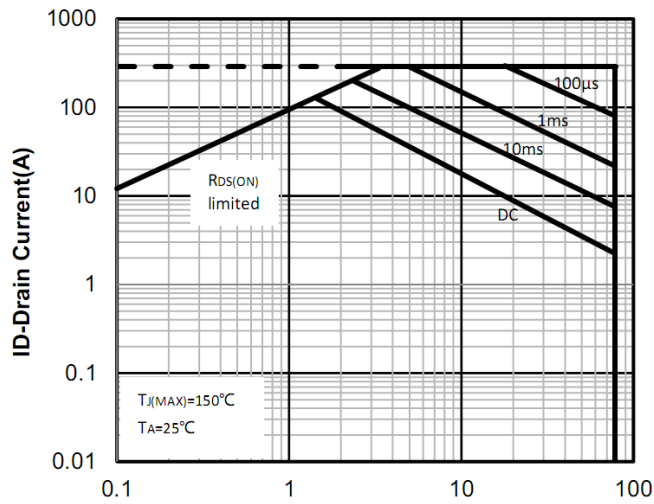

Figure9: VDS Drain-Source Voltage (V)

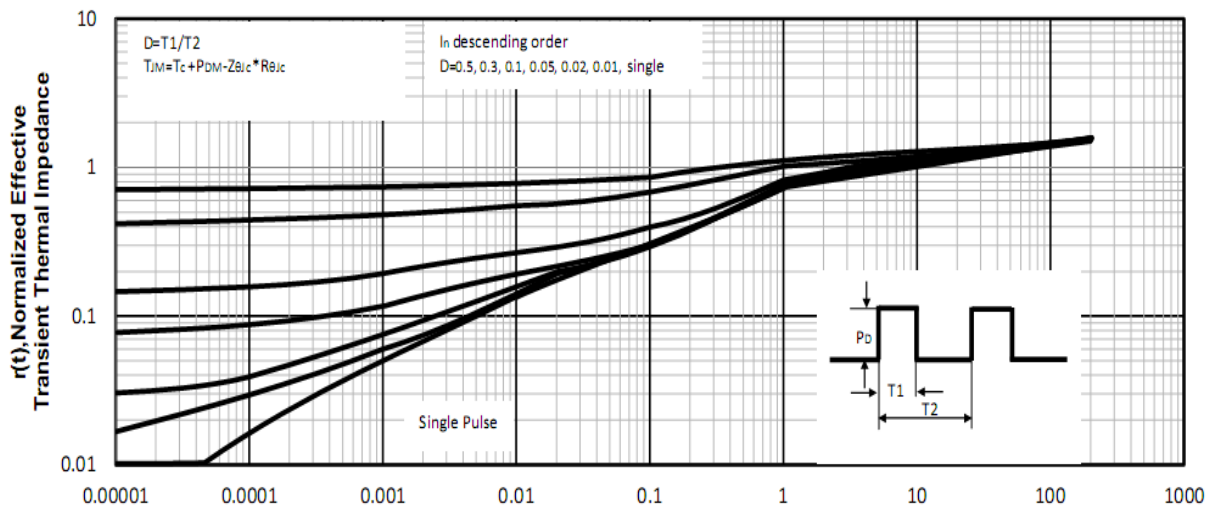
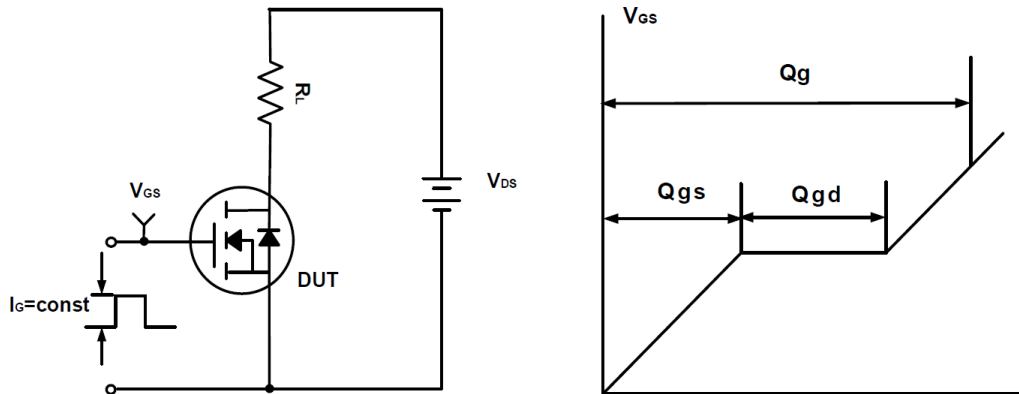
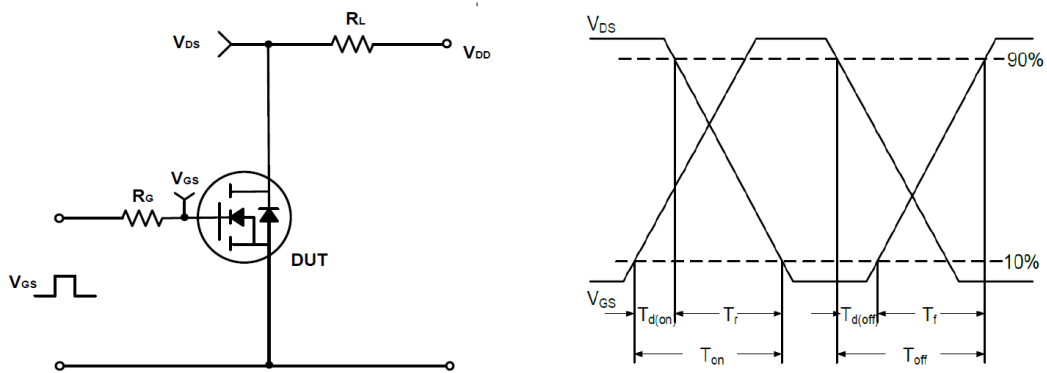
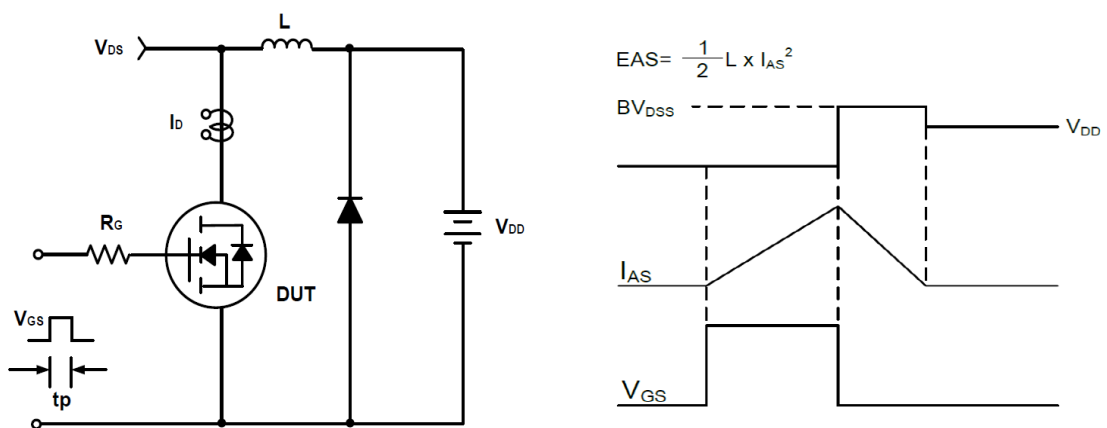

Figure10: Square Wave Pulse Duration (sec)

80V/90A N-Channel Advanced Power MOSFET
Test Circuit and Waveform:

Figure A Gate Charge Test Circuit & Waveforms

Figure B Switching Test Circuit & Waveforms

Figure C Unclamped Inductive Switching Circuit & Waveforms

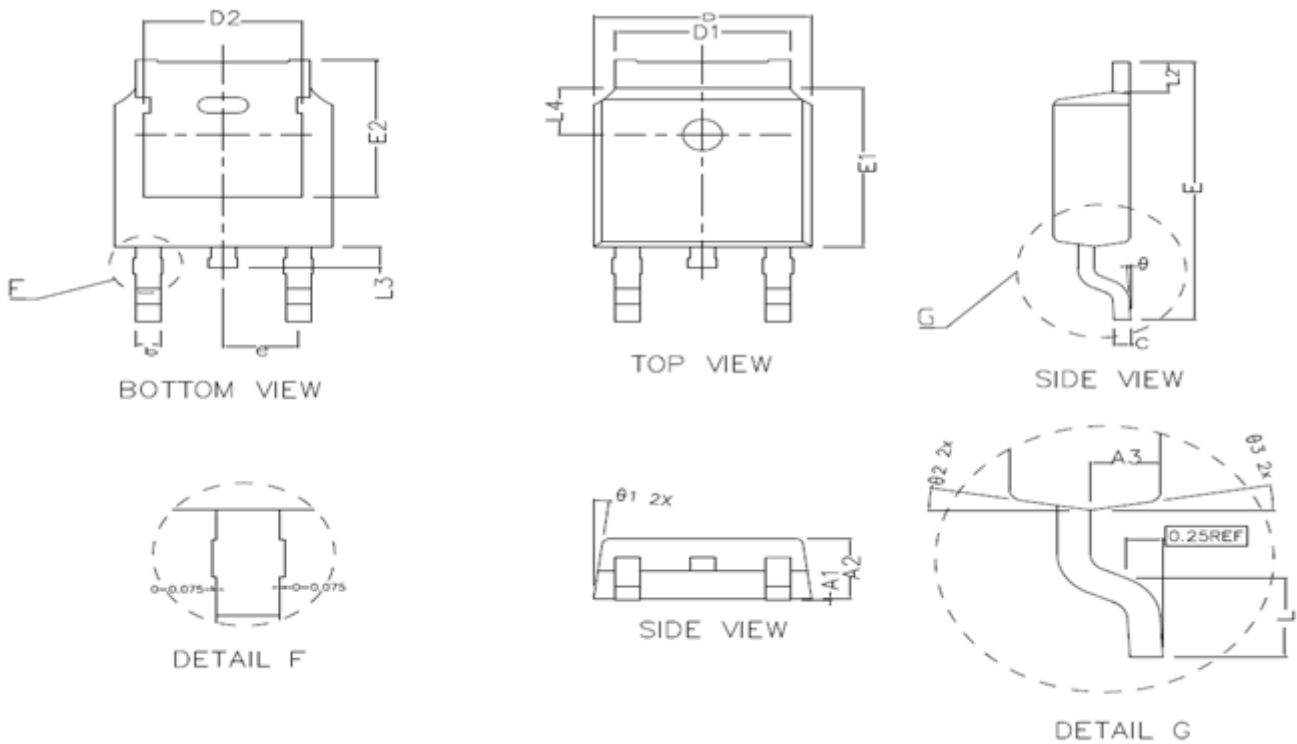

80V/90A N-Channel Advanced Power MOSFET

TO-252 Package Outline Dimensions (Units: mm)



COMMON DIMENSIONS (UNITS OF MEASURE IS mm)			
	MIN	NORMAL	MAX
A1	0.000	0.100	0.150
A2	2.200	2.300	2.400
A3	1.020	1.070	1.120
b	0.710	0.760	0.810
c	0.460	0.508	0.550
D	6.500	6.600	6.700
D1	5.330REF		
D2	4.830REF		
E	9.900	10.100	10.300
E1	6.000	6.100	6.200
E2	5.600REF		
e	2.286TYPE		
L	1.400	1.550	1.700
L2	1.10REF		
L3	0.80REF		
L4	1.80REF		
theta	0~8°		
theta1	7° TYPE		
theta2	10° TYPE		
theta3	10° TYPE		