

**-30V/-5.3A P-Channel Enhancement Mode MOSFET****Features**

- Advanced trench process technology
- High Density Cell Design For Ultra Low On-Resistance

BVDSS	-30	V
ID	-5.3	A
RDSON@VGS=-4.5V	54	mΩ
RDSON@VGS=-10V	38	mΩ

Applications

- PWM applications
- Load switch
- Power management

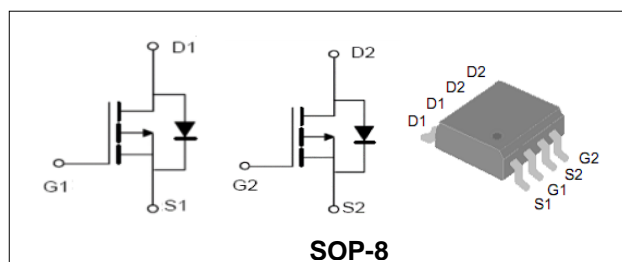
**Order Information**

Product	Package	Marking	Reel Size	Reel	Carton
PT4953	SOP-8	PT4953	13inch	3000PCS	48000PCS

Absolute Maximum Ratings

Symbol	Parameter	Rating	Unit
Common Ratings (TC=25°C Unless Otherwise Noted)			
$V_{(BR)DSS}$	Drain-Source Breakdown Voltage	-30	V
V_{GS}	Gate-Source Voltage	±20	V
T_J	Maximum Junction Temperature	150	°C
T_{STG}	Storage Temperature Range	-55 to 150	°C
I_S	Diode Continuous Forward Current	$T_A = 25^\circ\text{C}$ -5.3	A
Mounted on Large Heat Sink			
I_{DM}	Pulse Drain Current Tested (Silicon Limit) (Note1)	$T_A = 25^\circ\text{C}$ -20	A
I_D	Continuous Drain current	$T_A = 25^\circ\text{C}$ -5.3	A
P_D	Maximum Power Dissipation	$T_A = 25^\circ\text{C}$ 2.5	W
$R_{\theta JA}$	Thermal Resistance Junction-to-Ambient (Note2)	62.5	°C/W

**-30V/-5.3A P-Channel Enhancement Mode MOSFET**

Symbol	Parameter	Condition	Min.	Typ.	Max.	Unit
Static Electrical Characteristics @ T_J = 25°C (unless otherwise stated)						
V _{(BR)DSS}	Drain- Source Breakdown Voltage	VGS=0V ID=-250μA	-30	--	--	V
I _{DSS}	Zero Gate Voltage Drain current	VDS=-24V,VGS=0V	--	--	-1	μA
I _{GSS}	Gate-Body Leakage Current	VGS=±16V,VDS=0V	--	--	±100	nA
V _{GS(TH)}	Gate Threshold Voltage	VDS=VGS,ID=-250μA	-1	-1.7	-3	V
R _{DS(ON)}	Drain-Source On-State Resistance (Note3)	VGS=-4.5V, ID=-3.6A	--	54	90	mΩ
		VGS=-10V, ID=-4.5A	--	38	60	mΩ
g _{FS}	Forward Transconductance	VDS=-10V,ID=-5.3A	--	10	--	S
Dynamic Electrical Characteristics @ T_J = 25°C (unless otherwise stated) (Note4)						
C _{iss}	Input Capacitance	VDS= -15V, VGS=0V, F=1MHz	--	745	--	pF
C _{oss}	Output Capacitance		--	440	--	pF
C _{rss}	Reverse Transfer Capacitance		--	120	--	pF
Q _g	Total Gate Charge	VDS= -15V, ID= -5.3A, VGS= -10V	--	28	--	nC
Q _{gs}	Gate-Source Charge		--	3	--	nC
Q _{gd}	Gate-Drain Charge		--	7	--	nC
Switching Characteristics (Note4)						
t _{d(on)}	Turn-on Delay Time	VDD=-15V, RL=15Ω, ID=-1A, RG=6Ω, VGS=-10V	--	9	--	nS
t _r	Turn-on Rise Time		--	15	--	nS
t _{d(off)}	Turn-off Delay Time		--	75	--	nS
t _f	Turn-off Fall Time		--	40	--	nS
Source- Drain Diode Characteristics @ T_J = 25°C (unless otherwise stated)						
V _{SD}	Forward on voltage (Note3)	IS=-2.6A,VGS=0V	--	--	-1.3	V

Note:

1. Repetitive Rating: Pulse width limited by maximum junction temperature.
2. Surface Mounted on FR4 Board, t ≤ 10 sec
3. Pulse Test: pulse width ≤ 300 us, duty cycle ≤ 2%.
4. Guaranteed by design, not subject to production testing.



-30V/-5.3A P-Channel Enhancement Mode MOSFET

Typical Characteristics

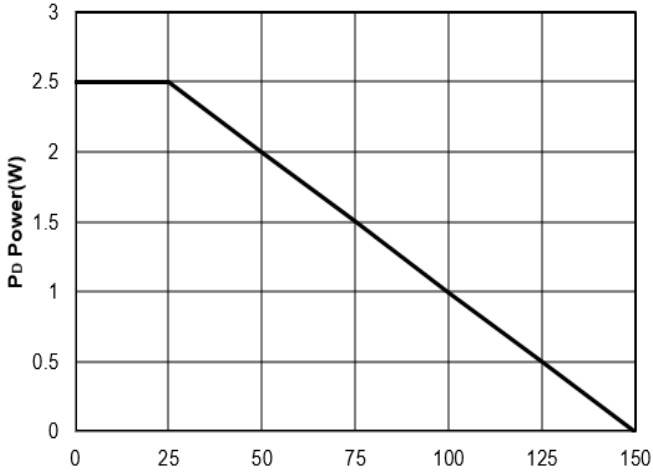

Figure1: T_j Junction Temperature (°C)

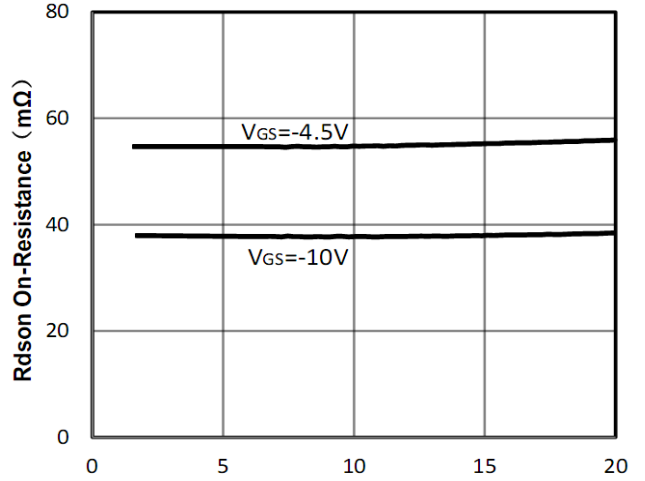

Figure2: -I_D Drain Current (A)

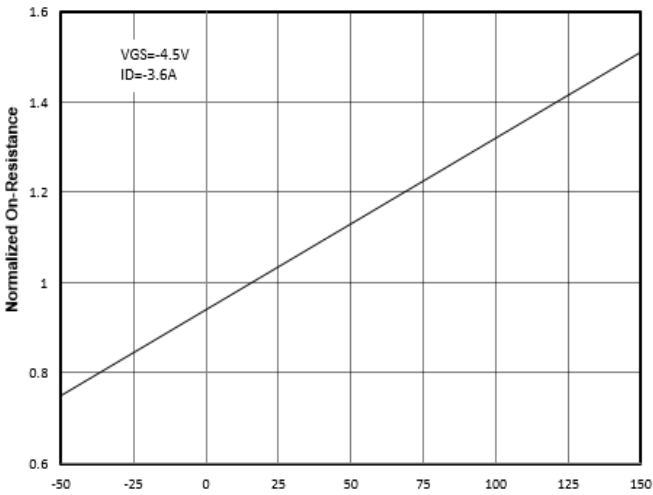

Figure3: T_j Junction Temperature (°C)

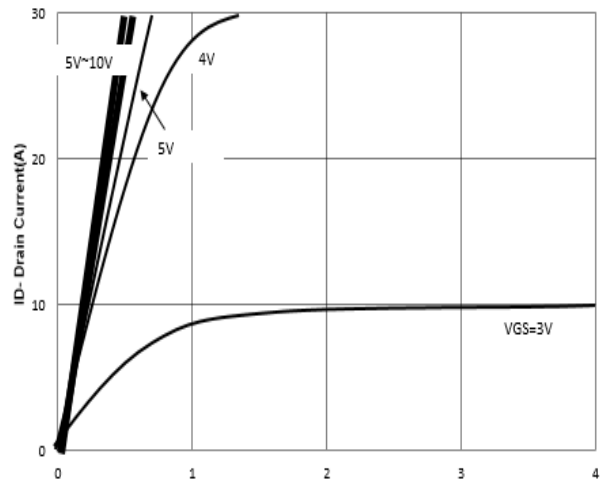

Figure4: -V_{ds} Drain-Source Voltage (V)

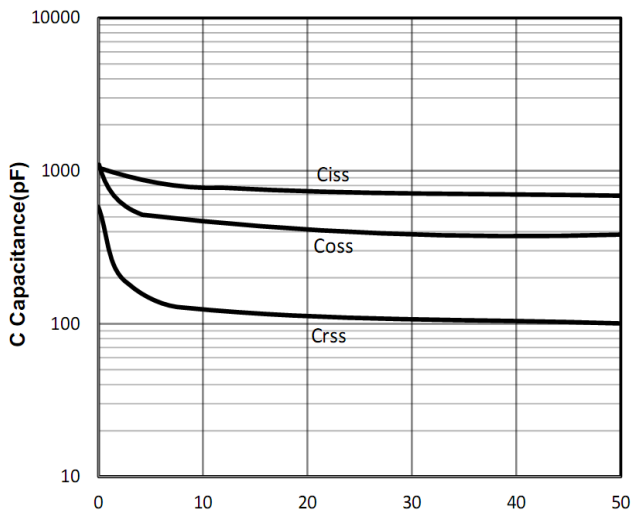

Figure5: -V_{ds} Drain-Source Voltage (V)

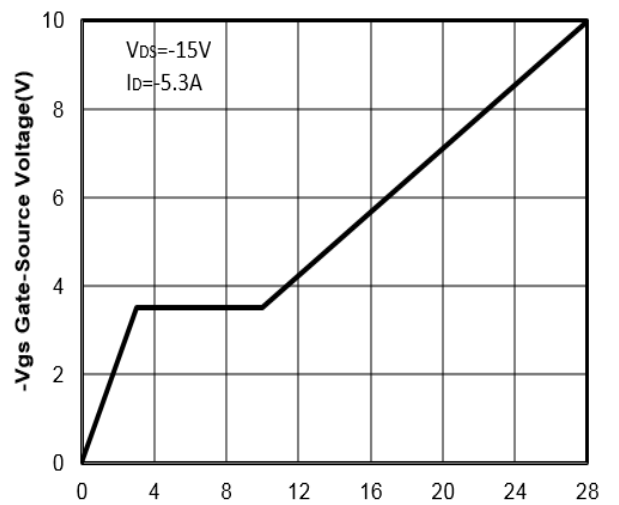

Figure6: Q_g Gate Charge (nC)

-30V/-5.3A P-Channel Enhancement Mode MOSFET

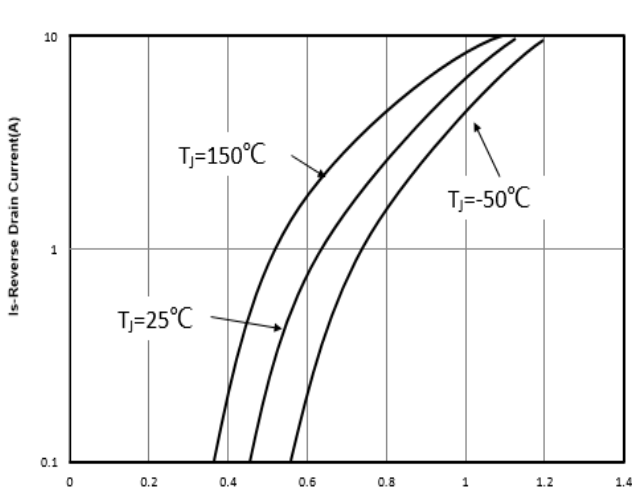

Figure7: Vsd Source-Drain Voltage (V)

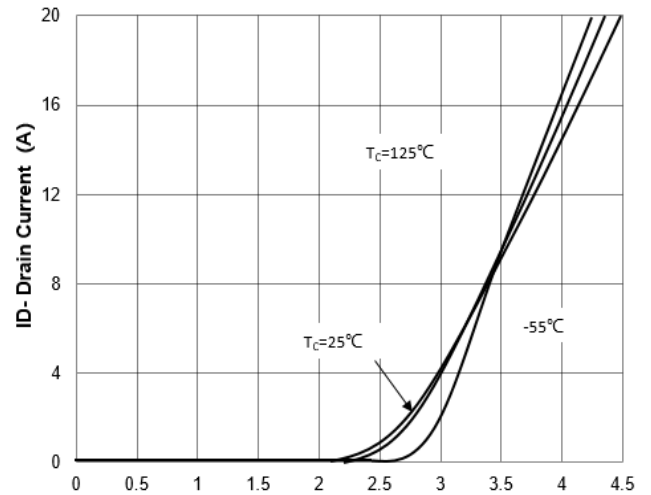

Figure8: Vgs Gate-Source Voltage (V)

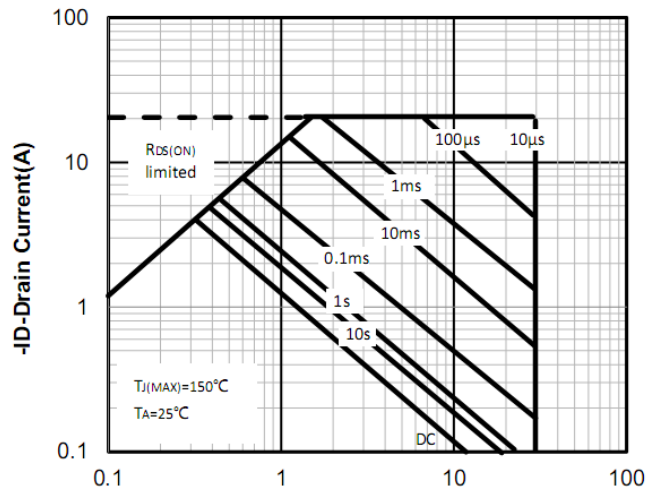

Figure9: -Vds Drain-Source Voltage (V)

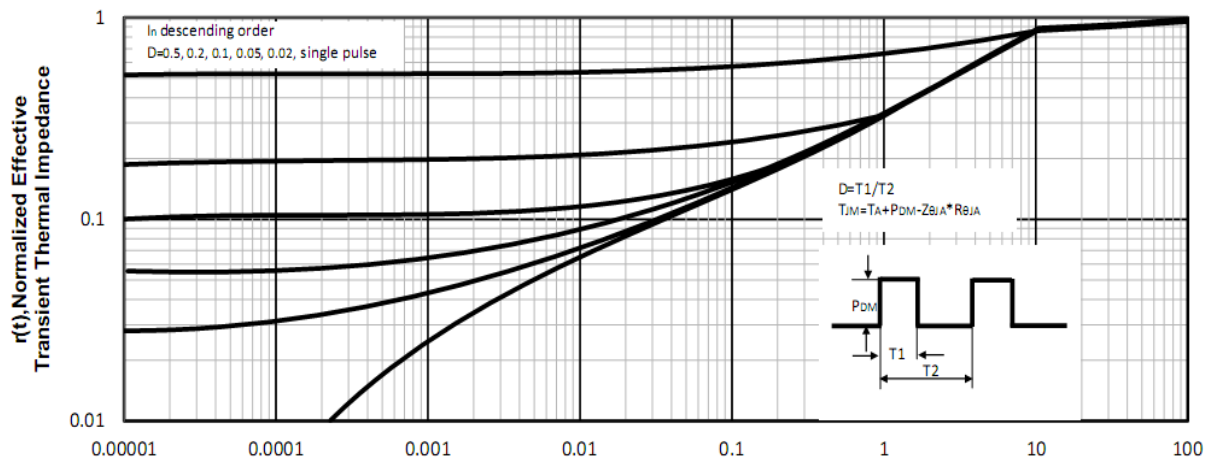

Figure10: Square Wave Pulse Duration (sec)

-30V/-5.3A P-Channel Enhancement Mode MOSFET

Test Circuit and Waveform:

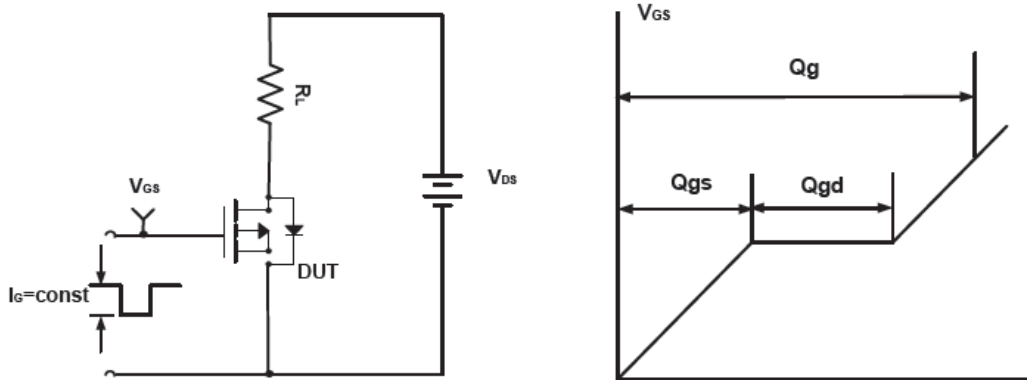

Figure A Gate Charge Test Circuit & Waveforms

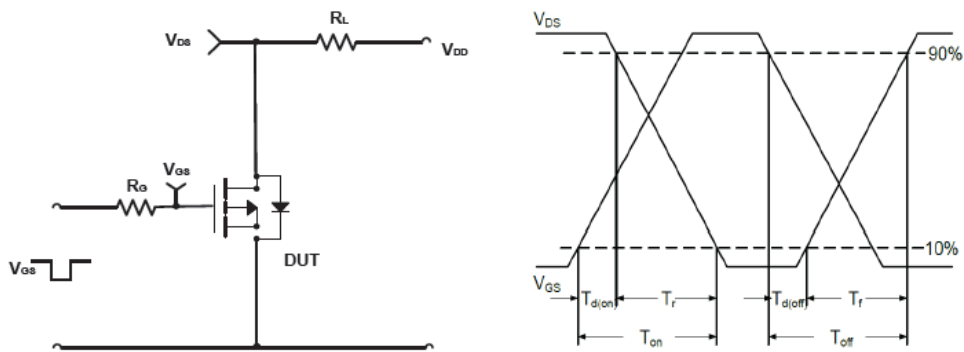

Figure B Switching Test Circuit & Waveforms

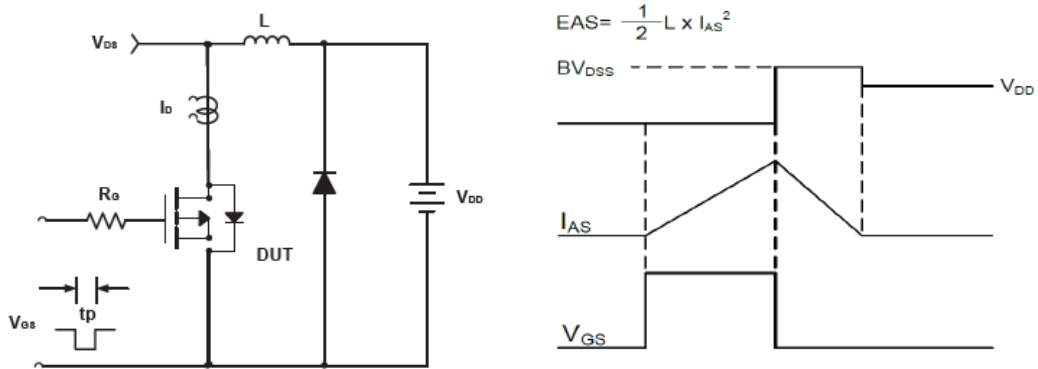
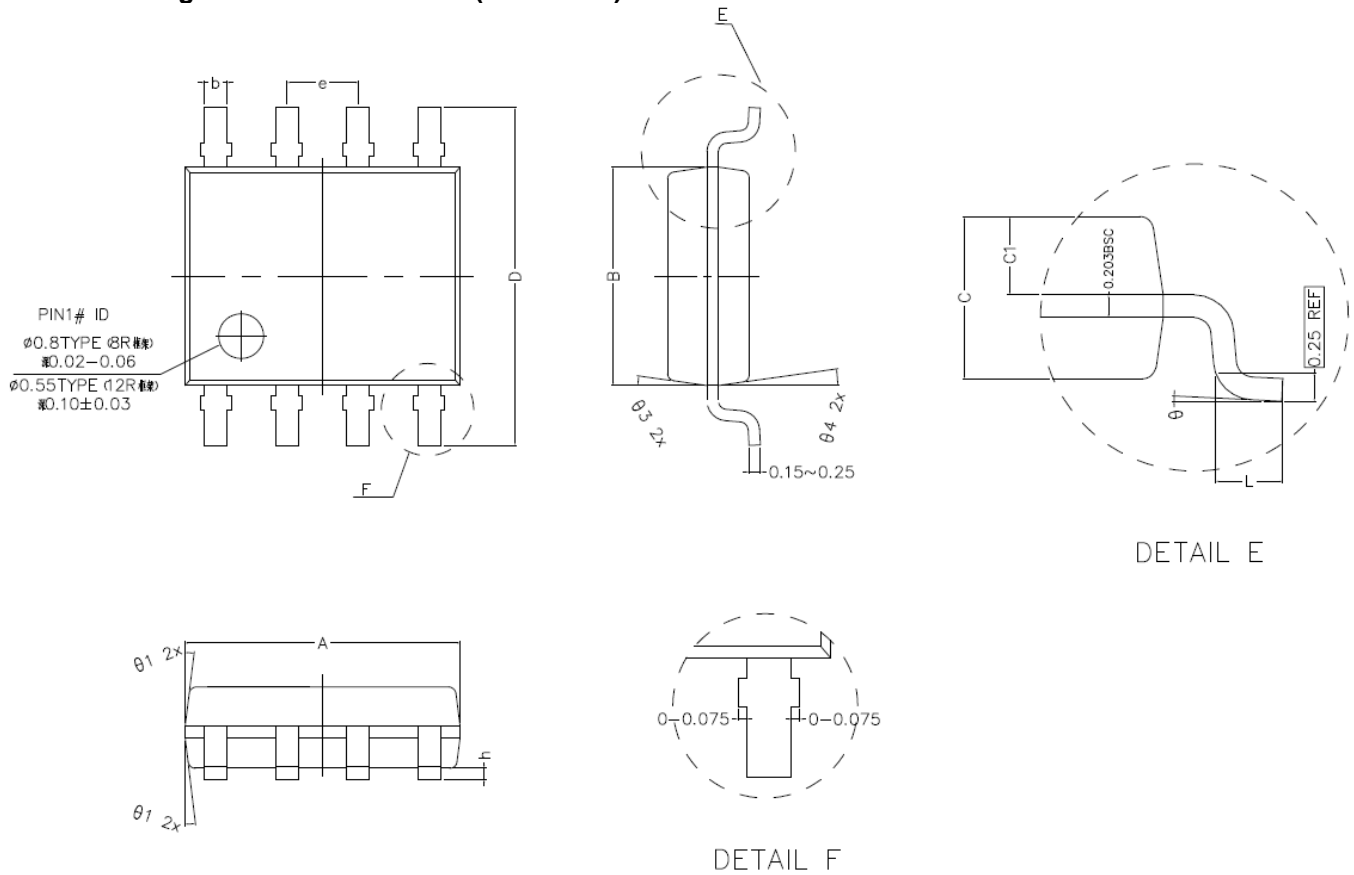

Figure C Unclamped Inductive Switching Circuit & Waveforms

-30V/-5.3A P-Channel Enhancement Mode MOSFET
SOP-8 Package Outline Dimensions (Units: mm)

COMMON DIMENSIONS (UNITS OF MEASURE IS mm)			
	MIN	NORMAL	MAX
A	4.800	4.900	5.000
B	3.800	3.900	4.000
C	1.350	1.450	1.550
C1	0.650	0.700	0.750
D	5.900	6.100	6.300
L	0.500	0.600	0.700
b	0.350	0.400	0.450
h	0.050	0.150	0.250
e	1.270TYPE		
θ_1	7° TYPE(8R)		12° TYPE(12R)
θ_2	7° TYPE(8R)		10° TYPE(12R)
θ_3	8° TYPE(8R)		12° TYPE(12R)
θ_4	8° TYPE(8R)		10° TYPE(12R)
θ	0° ~ 8°		